

Technical Data 1100C Series

1106C-E66TAG4

Electropak

Basic technical data

| | |
|---|---|
| Number of cylinders | 6 |
| Cylinder arrangement | in-line |
| Cycle | 4 stroke |
| Induction system | Turbocharged and air charge cooled |
| Combustion system | Direct injection diesel |
| Compression ratio | 16,2:1 |
| Bore | 105 mm |
| Stroke | 127 mm |
| Cubic capacity | 6,6 litres |
| Direction of rotation | Anticlockwise when viewed from flywheel |
| Firing order (number 1 cylinder furthest from flywheel) | 1 5 3 6 2 4 |
| Estimated total weight of Electropak (dry) | 788 kg |
| Estimated total weight of Electropak (wet) | 822 kg |

Overall dimensions - Electropak

| | |
|------------------------------|-----------|
| -height | 1140.4 mm |
| -length (air cleaner fitted) | 1763.2 mm |
| -width | 788.3 mm |

Moments of rotational inertia (mk²)

| | |
|------------------------------|-----------------------|
| Engine rotational components | 0.27 kgm ² |
| Flywheel | 1.26 kgm ² |

Centre of gravity - Electropak (wet)

| | |
|---|----------|
| Forward of rear face of cylinder block | 476,3 mm |
| Above crankshaft centre line | 176,4mm |
| Offset to RHS of crankshaft centre line | 16 mm |

Performance

Note: All data based on operation to ISO 3046-1:2002 standard reference conditions.

All ratings certified to within $\pm 3\%$
Speed variation at constant load $\pm 0,25\%$

Cyclic irregularity at 110% stand-by power

| | |
|---------------|-------|
| -1500 rev/min | 0.028 |
| -1800 rev/min | 0.020 |

Test conditions

| | |
|---|---------|
| -air temperature | 25 °C |
| -barometric pressure | 100 kPa |
| -relative humidity | 31.5% |
| -air inlet restriction at maximum power (nominal) | 5 kPa |
| -exhaust back pressure at maximum power (nominal) | 15 kPa |
| -fuel temperature (inlet pump) | 40 °C |

Sound level

Average sound pressure level for Electropak at 1 metre

| | |
|-----------------|-------------|
| -@ 1500 rev/min | 111,6 dB(A) |
| -@ 1800 rev/min | 113,0 dB(A) |

If the engine is to operate in ambient conditions other than those of the test conditions, suitable adjustments must be made for these changes. For full details, contact Perkins Technical Service Department.

Certified against the requirements of EU2007 legislation for non-road mobile machinery, powered by constant speed engines (EU97/68/EC Stage II)

General installation

| Designation | Units | Prime | Standby | Prime | Standby |
|---|---------------------|--------|---------|--------|---------|
| | | 50Hz | | 60Hz | |
| Gross engine power | kWm | 163,3 | 180,4 | 185,3 | 204,3 |
| Electropak nett engine power | kWm | 158,4 | 175,5 | 177,3 | 196,3 |
| Brake mean effective pressure | kPa | 1981,0 | 2189,0 | 1877,0 | 2065,0 |
| Engine coolant flow (against 35 kPa restriction) | l/min | 180,0 | | 216,0 | |
| Combustion air flow (at STP) | m ³ /min | 11,3 | 11,7 | 13,3 | 13,4 |
| Exhaust gas flow (Max.) | m ³ /min | 29,4 | 31,0 | 33,4 | 34,8 |
| Max. exhaust gas temperature in manifold after turbocharger | °C | 480 | 499 | 485 | 509 |
| Overall thermal efficiency (nett) | % | 39,3 | 39,8 | 38,1 | 38,8 |
| Typical genset electrical output (0.8pf 25 °C) | kWe | 147,3 | 163,2 | 164,9 | 182,6 |
| | kVA | 184,1 | 204,0 | 206,1 | 228,2 |
| Regenerative power (estimated) | kW | 8,8 | | 14,9 | |
| Assumed alternator efficiency | % | 93 | | | |
| Energy balance | | | | | |
| Energy in fuel | kWt | 403,8 | 442,3 | 467,5 | 508,0 |
| Energy in power output (gross) | kWb | 163,3 | 180,4 | 185,3 | 204,3 |
| Energy to cooling fan | kWm | 4,9 | | 8,0 | |
| Energy in power output (nett) | kWt | 158,4 | 175,5 | 177,3 | 196,3 |
| Energy to exhaust | kWt | 125,0 | 135,7 | 148,3 | 160,4 |
| Energy to coolant and oil | kWt | 72,8 | 79,8 | 82,2 | 89,5 |
| Energy to charge cooler | kWt | 30,2 | 32,7 | 37,2 | 38,1 |
| Energy to radiation | kWt | 12,5 | 13,7 | 14,5 | 15,7 |

1106C-E66TAG4 - Left side view

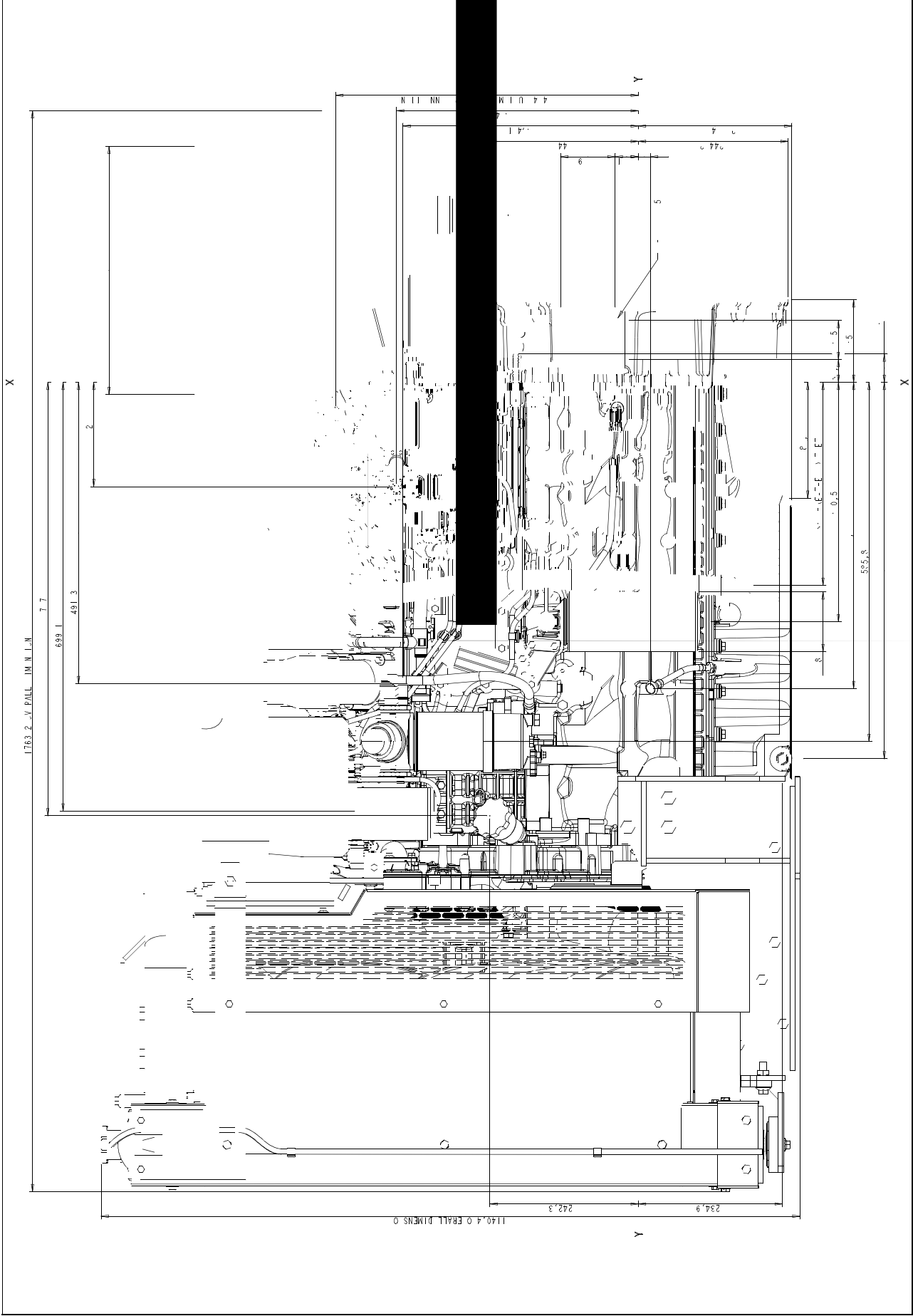

1106C-E66TAG4 - Front view

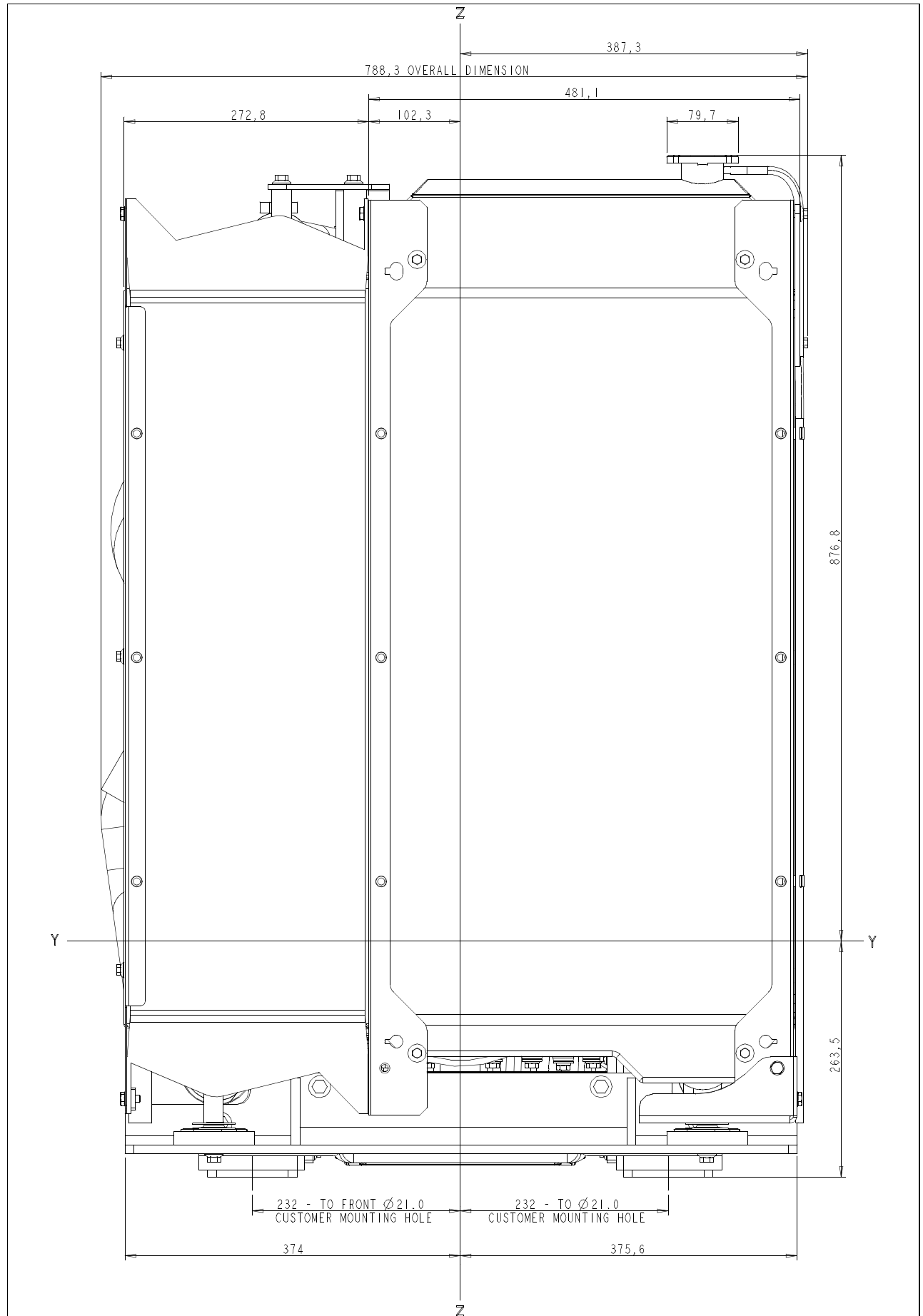

1106C-E66TAG4 - Right side view

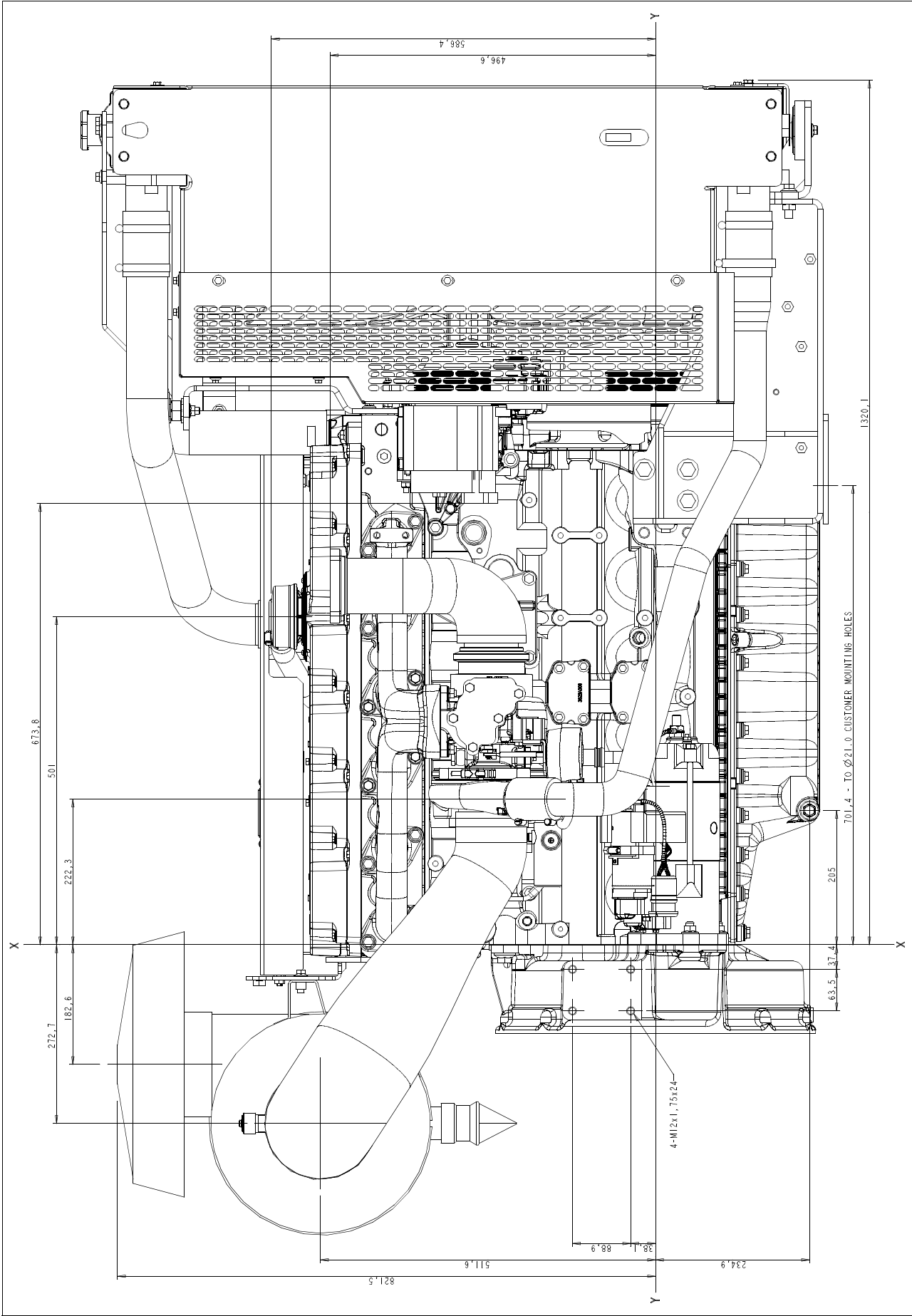

1106C-E66TAG4 - Rear view

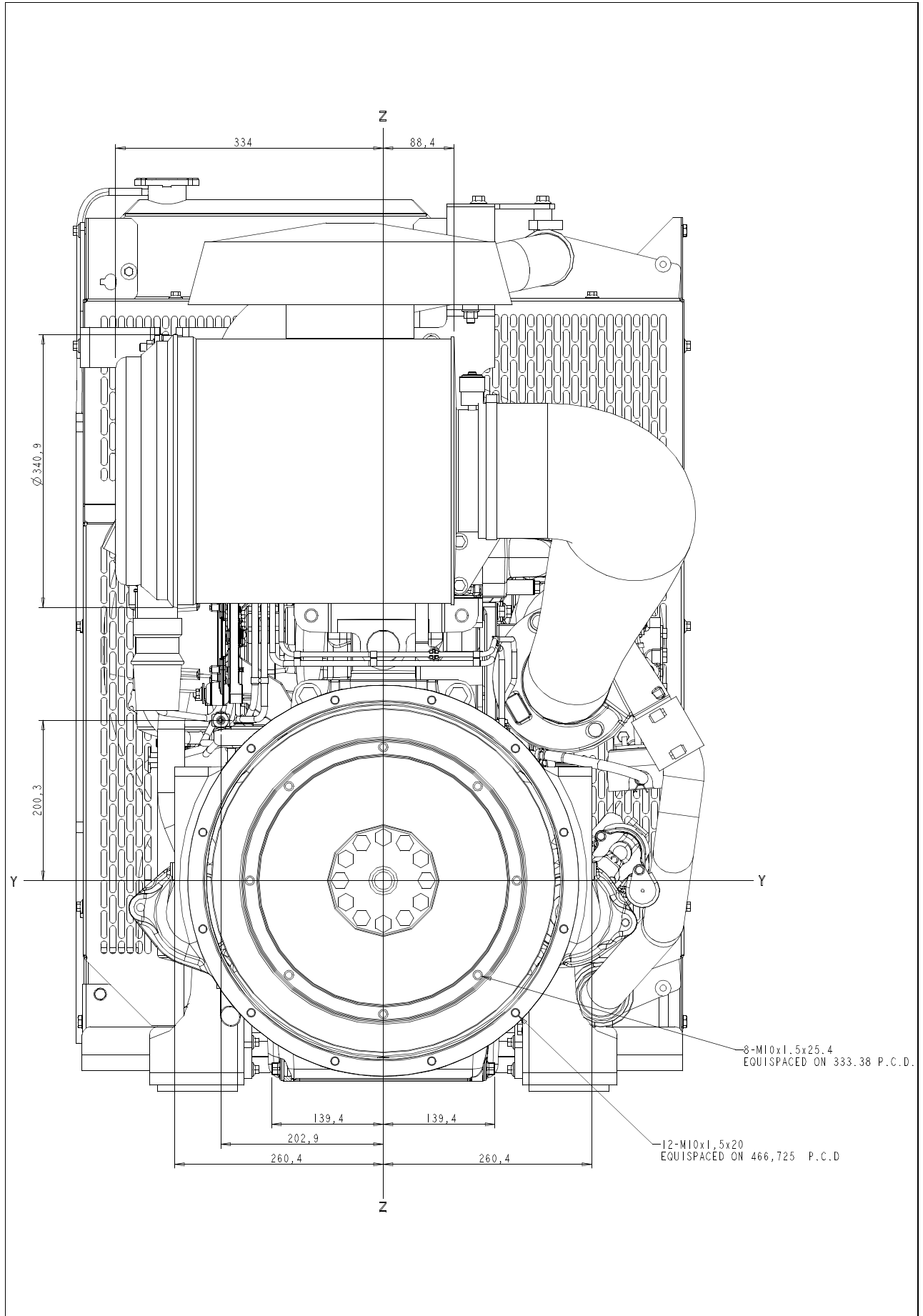

1106C-E66TAG4 - Plan view

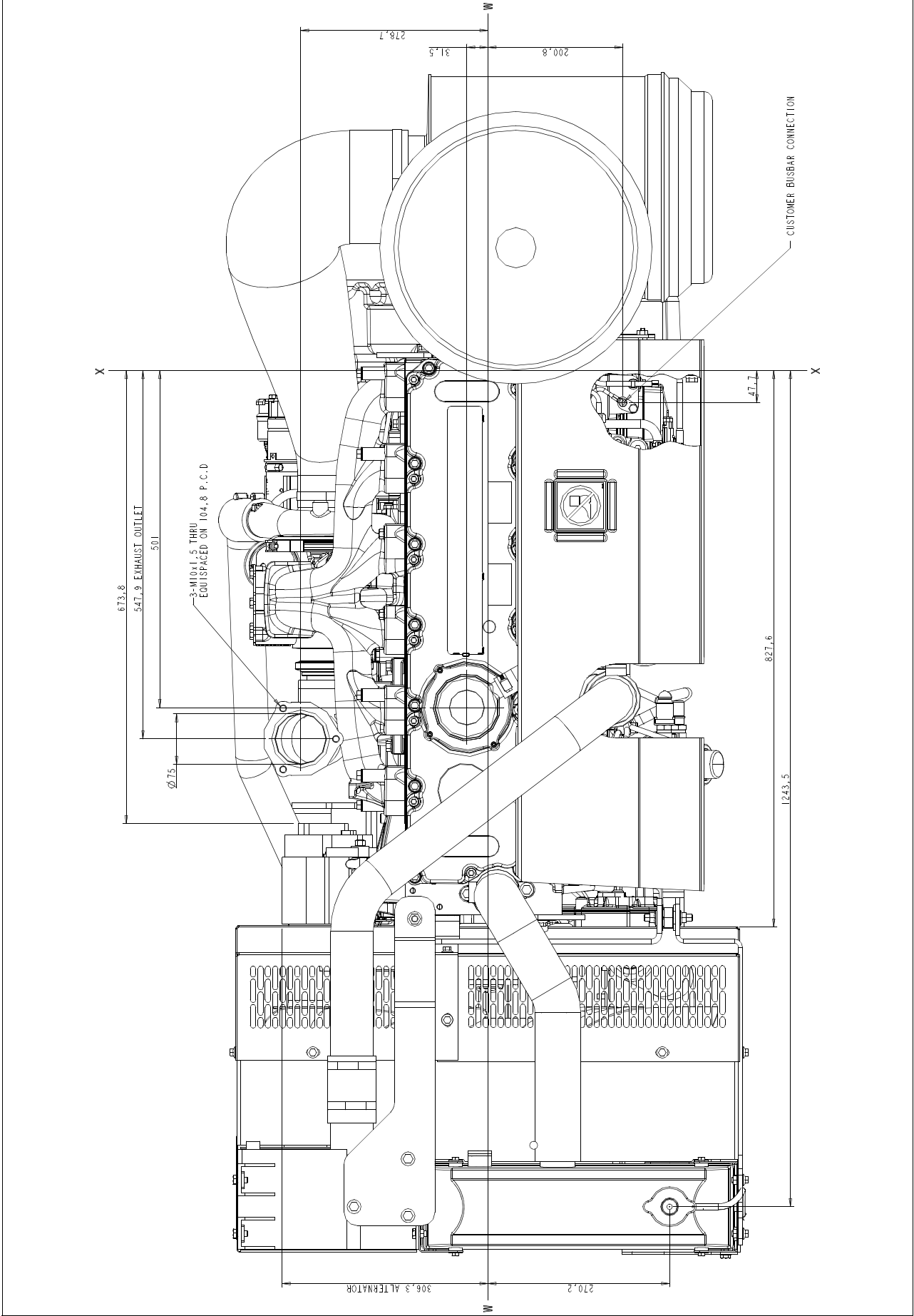

Cooling system

Cooling pack

-overall weight (wet) 71 kg
 -overall face area 554760 mm²
 -width 745 mm
 -height 1080 mm

Radiator

Face area 35120 mm²
 Number of rows and materials 5 rows, aluminium
 Matrix density and material 10 fins per inch, aluminium
 Width of matrix 439 mm
 Height of matrix 800 mm
 Pressure cap setting (min) 100 kPa

Charge cooler

Face area 203560 mm²
 Number of rows and materials 2 rows, aluminium
 Matrix density and material 10 fins per inch, aluminium
 Width of matrix 258 mm
 Height of matrix 789 mm

Fan

Diameter 686 mm
 Drive ratio..... 1.2:1
 Number of blades..... 7
 Material nylon
 Type..... pusher

Coolant

Total system capacity 21 litres
 System drawdown capacity 10%
 Engine capacity 9.5 litres
 Maximum top tank temperature 112 °C
 Temperature rise across engine
 Max. rating dependent 6.8 to 11.0 °C
 Max. permissible external system resistance 35 kPa
 Thermostat operation range..... 85 to 95 °C
 Shutdown switch setting 118 °C
 Coolant pump method of drive gears
 Recommended coolant immersion heater
 rating (minimum) 0.75 kW
 Recommended coolant: 50% anti freeze / 50% water. For complete
 details of recommended coolant specifications, refer to the
 Operation and Maintenance Manual for this engine model

Duct Allowance

| 1106C-E66TAG4 - Maximum additional restriction (Duct allowance to cooling airflow and resultant min. airflow (Standby power)) | | | |
|---|---------|-------|---------------------|
| Duct allowance with inhibited coolant at 50 °C | | | |
| Description | rev/min | kPa | m ³ /min |
| Duct allowance | 1500 | 0,125 | 281 |
| | 1800 | 0,125 | 314 |
| Duct allowance with inhibited coolant at 43 °C | | | |
| Minimum airflow | 1500 | 0,200 | 281 |
| | 1800 | 0,200 | 314 |

Electrical system

Alternator.....Denso A127i
 Alternator voltage 12 volts
 Alternator output 100 amps
 StarterIskra AZF
 Starter motor voltage 12 volts
 Starter motor power 4.0 kW
 Number of teeth on the flywheel 126
 Number of teeth on the starter pinion 10
 Max. pull-in current of starter motor solenoid 62 amps
 Max hold-in current of starter motor solenoid @ 0°C 14 amps

Engine stop method via ECM
Note: All leads rated at 10 amps minimum.

Cold start recommendations

Minimum required cranking speed over TDC 100 rev/min

Cold start recommendations

| Starter Model | At Temp. °C | Oil viscosity limit | Minimum Battery CCA (Cold Cranking Amps) | |
|---------------|-------------|---------------------|--|--------------------|
| | | | With glow plugs (SAE) | Without glow plugs |
| AZF (i) | -5 | 15W40 | 750 | 750 |
| AZF (i) | -10 | 15W40 | 850 | 950 |
| AZF (i) | -15 | 15W40 | 1500 | (ii) |
| AZF (i) | -20 | 10W | 1500 | (ii) |
| AZF (i) | -25 | 5W30 | 1900 | (ii) |

i.AZF starter - Battery must not exceed 2400 CCA.

ii.Glow plugs must be used.

Note: The table above shows the recommended battery sizes against starter model, temperature and oil viscosity and is based on the test results from starting a 'bare' engine with batteries at a 75% state of charge and with a cable resistance of 0,0017 Ohms.

Induction system

Maximum air intake restriction

-clean filter.....5 kPa
 -dirty filter8 kPa
 -air filter type..... paper element

Exhaust system

Maximum back pressure

-1500 rev/min10.0 kPa
 -1800 rev/min15.0 kPa
 Exhaust outlet, internal diameter 90 mm

Fuel system

Injection components

Injector electronic
 Fuel pump CR200

Fuel priming

Priming pump type manual / electronic
 Maximum priming time 90 seconds

Fuel feed

Maximum fuel flow..... 1.5 l/min
 Maximum suction head at engine fuel pump inlet 30 kPa
 Maximum static pressure head 600 kPa
 Fuel temperature at engine fuel pump inlet 80 °C
 Tolerance on fuel consumption 3%

Fuel specification

Perkins recommend the use of the following fuel specifications:

- EN590 DERV Grade A, B, C, E, F, Class 0, 1, 2, 3 & 4
- BS2869 Class A2 Off-highway Gas Oil Red Diesel
- ASTM D975, Class 1D and Class 2D

Note: For further information on fuel specifications and restrictions, refer to P.5 of the OMM Fuels section for this engine model

Fuel consumption

| Load | Type of operation and application | | | |
|------------|-----------------------------------|------------------------|----------------------|----------------------|
| | 1500 rev/min g/kWhr | 1800 rev/min g/kWhr | 1500 rev/min l/hr | 1800 rev/min l/hr |
| Standby | 204,9 | 207,5 | 44,0 | 50,5 |
| 110% prime | 205,1 | 208,0 | 43,8 | 50,4 |
| Prime | 206,9 | 211,1 | 40,2 | 41,3 |
| 75% prime | 212,7 | 222,7 | 31,0 | 36,8 |
| 50% prime | 211,6 | 231,6 | 20,5 | 25,5 |

Note: Based on gross rated power

Lubrication system

Maximum total system oil capacity 16.5 litres
 Minimum oil capacity in sump 12.5 litres
 Maximum oil capacity in sump 15.5 litres
 Maximum engine operating angles -
 front up, front down, right side, left side 25 °
 Sump drain plug tapping size. 3/4 - 16 UNF
 Shutdown switch setting (where fitted) ECM controlled

Lubricating oil

-relief valve opening pressure 430 kPa
 -pressure at maximum speed 450 kPa
 -maximum continuous oil temperature (in rail) 125 °C
 -oil consumption at full load (% of fuel) < 0.1

Recommended SAE viscosity

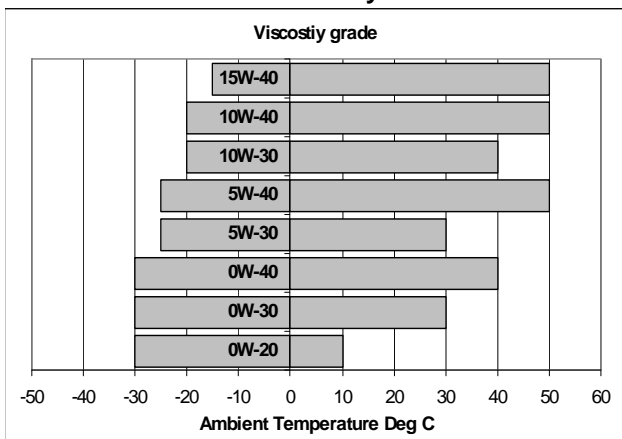

A multigrade oil must be used which conforms to API-CH4/CI4.

Mountings

Maximum static bending moment at
 -rear face of block 1130 Nm
 Maximum permissible overhung load
 -on the flywheel TBA Nm
 Maximum bending moment at rear
 -of flywheel housing in shock +/-4200 Nm

Load acceptance

The below complies with the requirements of classification 3 and 4 of ISO 8528-12 and G2 operating limits stated in ISO 8528-5

| Initial load application: when engine reaches rated speed (15 seconds maximum after engine starts to crank) | | | |
|--|---------|----------------------|----------------------|
| Descriptor | Units | 1500 rev/min (50 Hz) | 1800 rev/min (60 Hz) |
| % of Prime Power | % | 55 | 50 |
| Load | kWe | 81,0 | 82,4 |
| Transient frequency deviation | % | ≤ 10 | ≤ 10 |
| Frequency recovery | seconds | 5 | 5 |

The above figures were obtained under the following test conditions:

-minimum engine block temperature 23°C
 -alternator efficiency 93 %
 -ambient temperature 23 °C
 -governing mode Isochronous
 -alternator inertia 1.32 kgm²
 -under frequency roll off (UFRO) point set to 1 Hz below rated
 -UFRO rate set to 2% voltage / 1% frequency
 LAM on/off Off
 All tests were conducted using an engine which was installed and serviced to Perkins Engines Company Limited recommendations
Note: The general arrangement drawings shown in this data sheet are for guidance only. For installation purposes, latest versions should be requested from the Applications Dept., Perkins Engines Stafford, ST16 3UB United Kingdom.



Perkins Engines Company Limited
 Peterborough PE1 5NA United Kingdom
 Telephone +44 (0) 1733 583000
 Fax +44 (0) 1733 582240
 www.perkins.com

Distributed by

All information in the document is substantially correct at the time of printing but may be subsequently altered by the company.